

ACOUSTIC WALL MOUNT

Series: 3900/01



- Easy to install on any profile point.
- Corrects unevenness in structure.
- SE-3901/TD1 profile can be bent to fit smaller spaces.
- Double TPE body provides additional support.
- Optimal load: 8kg to 30kg per mount.
- Suited for C type or stud walls above 3m in height.

MATERIAL

- Polymer Body: Kraiburg TPE
- Metal structure: Steel DC04
- Metal bowl leveller: Dx54d + Z140
- Oval bumper: Dx54d + Z140 steel with CAU EPDM 130 RE-42.

- [PERFORMANCE DATA](#)

- [TPE PROPERTIES](#)

- [APPLICATION GUIDE](#)

SE-3900-TD2

- Load range (C¹): Force moving away from wall – 5-25kg
- Load range (C¹): Force pressed against wall – 8-45kg
- [ENGINEERING DRAWING](#)

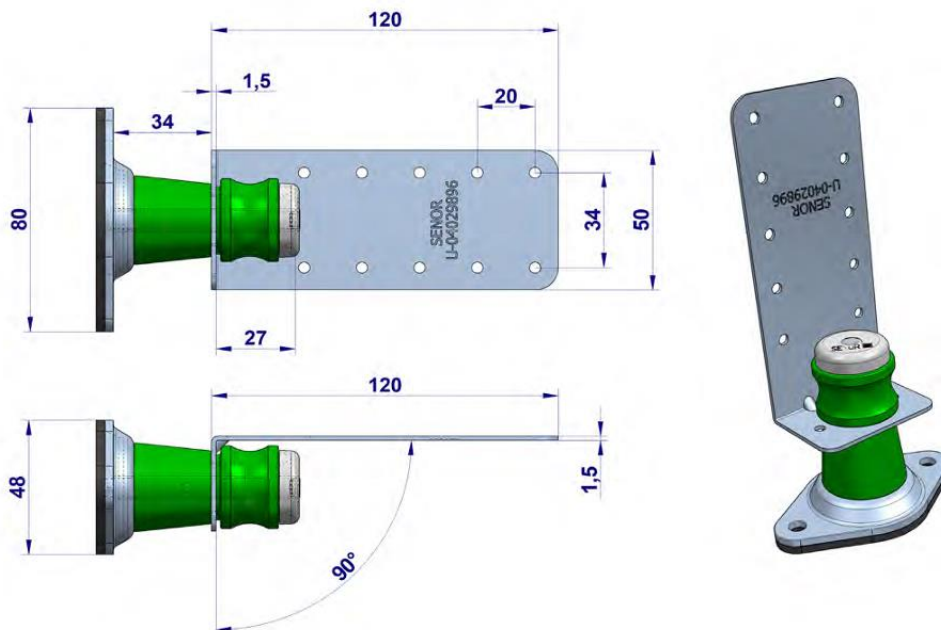

SE-3901/TD2

- Load range (C¹): Force moving away from wall – 5-25kg
- Load range (C¹): Force pressed against wall – 8-45kg
- [ENGINEERING DRAWING](#)

